

Model No.HP2050 2-SPEED HAMMER DRILL 20MM

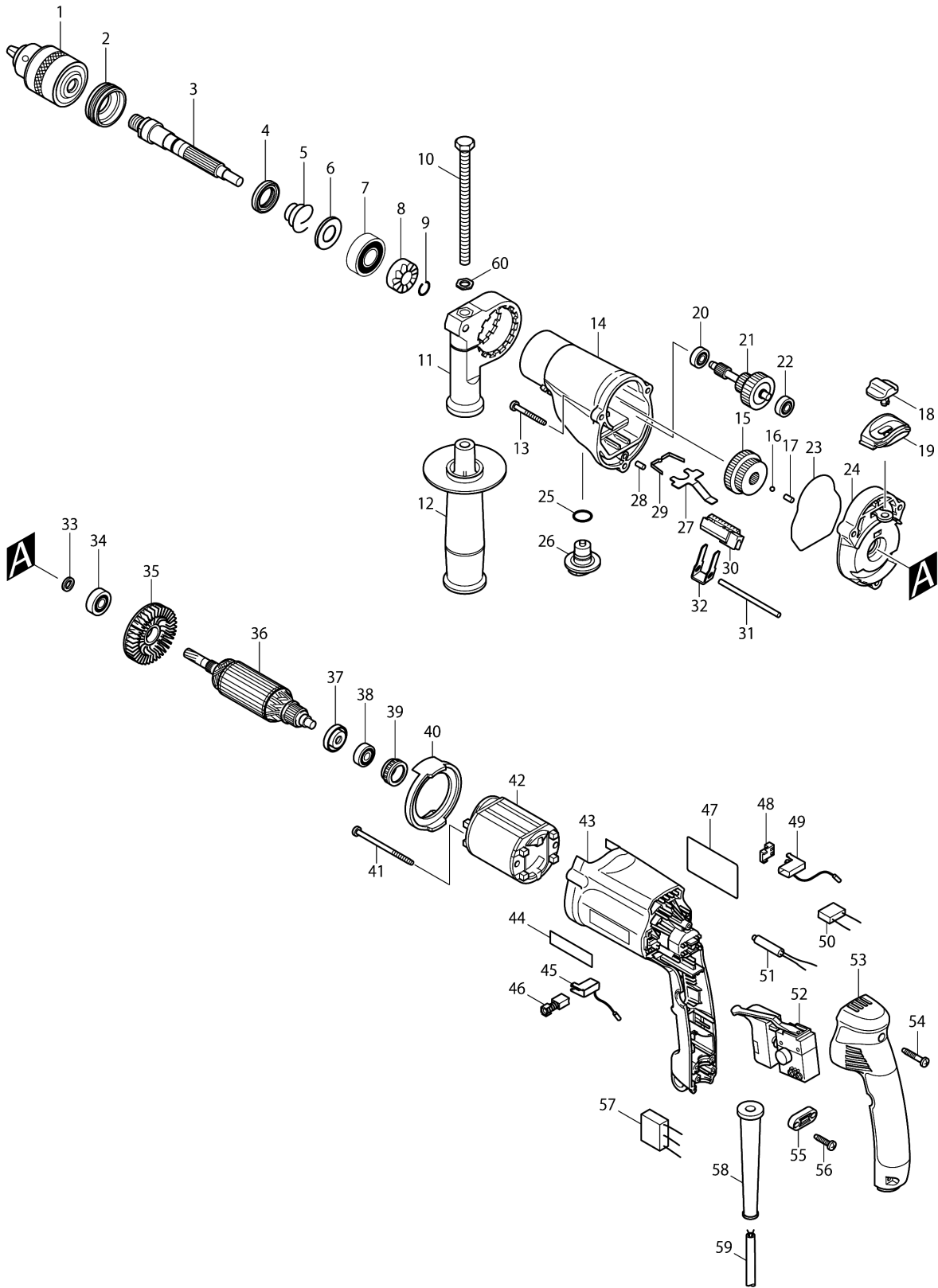

Model No.HP2050 2-SPEED HAMMER DRILL 20MM

Position	Artikel-Nr.	Beschreibung	I/C	Stk.	New/Old	Opt. 1	Opt. 2	Hinweis
001	193067-6	DRILL CHUCK & KEY SET		1	*			
001-1	193822-6	DRILL CHUCK S13	O	1				
C10	763430-3	CHUCK KEY S13		1				
002	285839-4	BEARING RETAINER		1				
003	324247-5	SPINDLE		1				
004	213314-0	OIL SEAL 19		1				
005	233921-3	CONICAL COMPRESSION SPRING		1				
006	345224-4	CUP WASHER 15		1				
007	211206-7	BALL BEARING 6202LLB		1				
008	223137-8	CAM A		1				
009	233920-5	RING SPRING 11		1				
010	921923-8	HEX. BOLT M8X120		1				
011	417630-4	GRIP BASE		1	*			
011-1	417630-4	GRIP BASE	O	1				
012	152521-9	GRIP 36 COMPLETE		1	*			
012-1	134943-5	GRIP 36 ASS'Y	<	1	*			
C10	152521-9	GRIP 36 COMPLETE		1	*			
D10		INC. 10,11			*			
012-2	134943-5	GRIP 36 ASS'Y	<	1	*			
C10	152521-9	GRIP 36 COMPLETE		1	*			
D10		INC. 10,11,60			*			
012-3	135302-6	GRIP 36 ASS'Y	O	1				
C10	153503-4	GRIP 36 COMPLETE		1				
D10		INC. 10,11,60						
013	266053-1	TAPPING SCREW 4X35		3				
014	153379-9	GEAR HOUSING COMPLETE		1				
015	227030-8	SPUR GEAR 29-37		1				
016	216001-0	STEEL BALL 3.5		1				
017	256251-5	PIN 4		1				
018	417801-3	CHANGE LEVER A		1	*			
018-1	418083-0	CHANGE LEVER A	<	1				
019	417802-1	LEVER CASE		1				
020	211014-6	BALL BEARING 606		1	*			
020-1	211012-0	BALL BEARING 606ZZ	O	1				
021	153363-4	GEAR COMPLETE		1	*			
021-1	153622-6	GEAR COMPLETE	O	1				
022	211014-6	BALL BEARING 606		1	*			
022-1	211012-0	BALL BEARING 606ZZ	O	1				
023	421810-6	SEAL RING		1				
024	153364-2	GEAR HOUSING COVER COMPLETE		1	*			
024-1	153620-0	GEAR HOUSING COVER COMPLETE	<	1				

Please order the parts with part number.

Print Date 7/9/2020

Model No.HP2050 2-SPEED HAMMER DRILL 20MM

Position	Artikel-Nr.	Beschreibung	I/C	Stk.	New/Old	Opt. 1	Opt. 2	Hinweis
025	213162-7	O RING 14		1	*			
025-1	213122-9	O RING 12	O	1				
026	417805-5	CHANGE LEVER B		1				
027	345225-2	LOCK PLATE		1				
028	256251-5	PIN 4		1				
029	232143-2	LEAF SPRING		1				
030	417804-7	RACK 12		1				
031	268092-7	PIN 4		1				
032	345223-6	CHANGE PLATE B		1				
033	262087-2	RING 8		1				
034	210005-4	BALL BEARING 608DDW		1				
035	241881-5	FAN 52		1				
036	517414-1	ARMATURE ASS'Y 220-240V		1				
D10		INC. 33,34,35,37,38						
037	681636-0	INSULATION WASHER		1				
038	211021-9	BALL BEARING 607LLB		1				
039	421494-0	RUBBER RING 19		1				
040	417803-9	BAFFLE PLATE		1				
041	266060-4	TAPPING SCREW 4X65		2				
042	633528-9	FIELD 220-240V		1				
043	183453-9	MOTOR HOUSING		1	*			
D10		INC. 44			*			
043-1	417807-1	MOTOR HOUSING	O	1				
044	819063-3	MAKITA LABEL		1	*			
045	643989-5	BRUSH HOLDER		1				
046	191962-4	CARBON BRUSH CB-419		1				
047	853858-4	NAME PLATE HP2050		1				
048	689111-0	SPACER		2				
049	643988-7	BRUSH HOLDER		1				
050	645105-5	NOISE SUPPRESSOR		1	*			
050-1	645200-1	NOISE SUPPRESSOR	S	1				
051	646133-3	CHOKE COIL		1	*			
052	650524-2	SWITCH TG813ALB-2		1				
053	153284-0	HANDLE COVER COMPLETE		1				
C10	263002-9	RUBBER PIN 4		2				
054	265999-8	TAPPING SCREW 4X25		3				
055	687052-4	STRAIN RELIEF		1	*			
055-1	687124-5	STRAIN RELIEF	O	1				
056	265995-6	TAPPING SCREW 4X18		2				
057	645253-0	NOISE SUPPRESSOR		1	*			
058	682559-5	CORD GUARD 8		1				
059	665394-6	POWER SUPPLY CORD 1.0-2-2.5		1				

Please order the parts with part number.

Print Date 7/9/2020

Model No.HP2050 2-SPEED HAMMER DRILL 20MM

Position	Artikel-Nr.	Beschreibung	I/C	Stk.	New/Old	Opt. 1	Opt. 2	Hinweis
060	345280-4	HEX. WASHER		1				
061	263002-9	RUBBER PIN 4		1				
A01	324219-0	DEPTH GAUGE		1				
A02	410102-8	KEY HOLDER		1				
A03	824650-5	PLASTIC CARRYING CASE		1				
C10	417724-5	LATCH		2				
C20	819144-3	MAKITA LOGO LABEL		1				
A04	763430-3	CHUCK KEY S13		1				
A06	806X02-6	HP2050 INDICATION LABEL		1				

Please order the parts with part number.

Print Date 7/9/2020