

Model No.DA3010F ÚHLOVÁ VRTAČKA 10MM

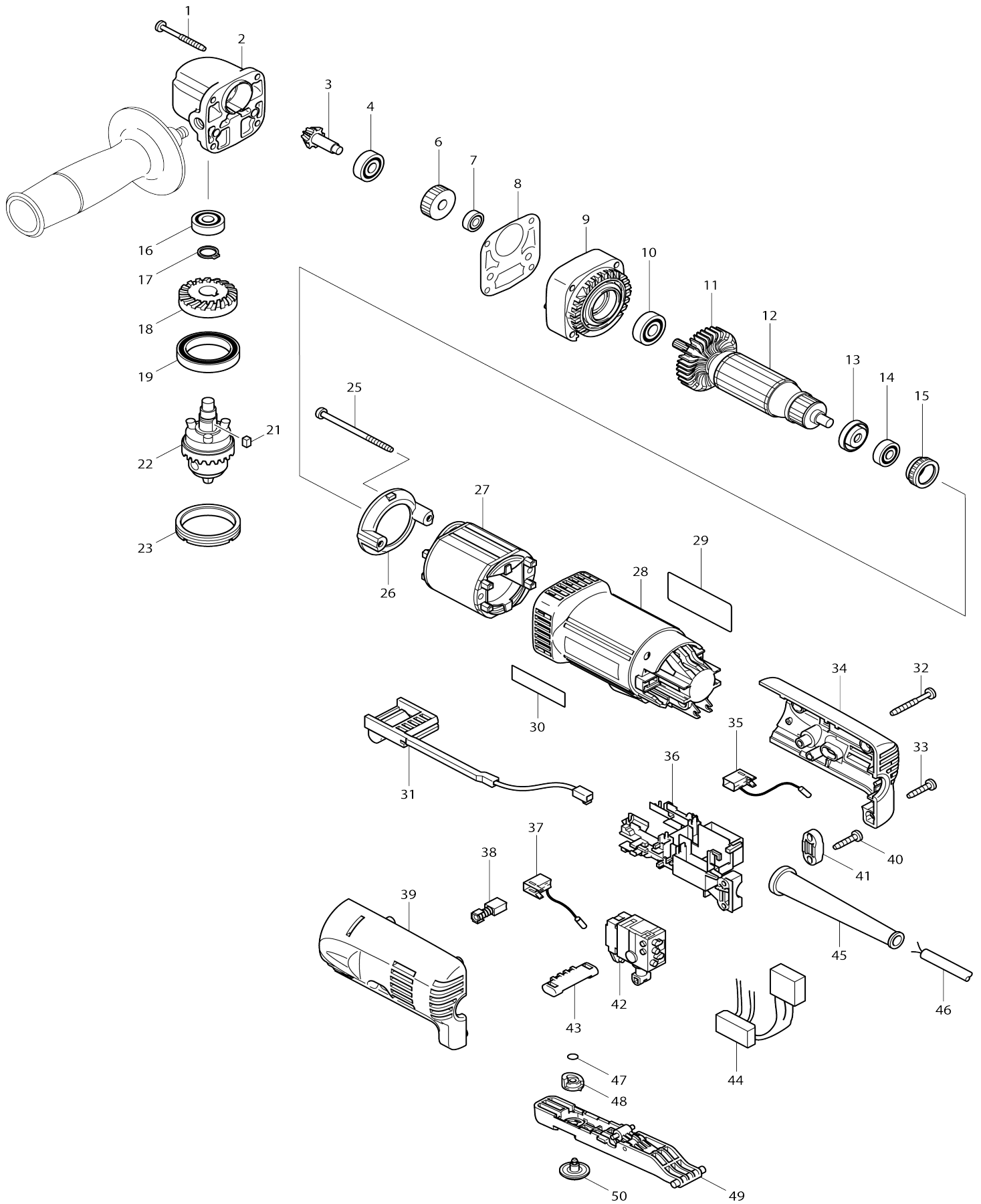

Model No.DA3010F ÚHLOVÁ VRTAČKA 10MM

Obj. č.	Obj. č.	Popis	Možn ost zá měny	Množ ství	Nový/ Starý	Poznámka 1	Poznámka 2
001	266048-4	šroub 4x40		4			
002	317635-3	hlava DA3010F		1	*	hlava DA3010F	
002-1	317635-3	hlava DA3010F	O	1		hlava DA3010F	
003	227436-0	ozubené kolo DA3010F		1		ozuben	
004	211031-6	BALL BEARING 608LLB		1	*	kuli	
004-1	210029-0	BALL BEARING 608ZZ	O	1			
006	226567-2	HELICAL GEAR 28		1		ozuben	
007	210026-6	kuličkové ložisko 696ZZ =old 210006-2		1		kuli	
008	418036-9	těsnění		1		t	
009	418042-4	GEAR HOUSING COVER		1		kryt	
010	211051-0	kuličkové ložisko 609LLB		1		kuli	
011	240061-0	FAN 48		1		ventil	
012	517583-8	rotor DA3010F		1		rotor DA3010F	
012		INC. 10,11,13,14					
013	681636-0	izolační podložka = old 681667-9		1		izola	
014	211021-9	BALL BEARING 607LLB		1			
015	421494-0	vymezovací kroužek		1		vymezovac	
016	211031-6	BALL BEARING 608LLB		1	*	kuli	
016-1	210029-0	BALL BEARING 608ZZ	O	1			
017	961052-5	segrovka vnější S-12		1		segrovka	
018	227437-8	ozubené kolo DA3010F		1		ozuben	
019	211419-0	kuličkové ložisko 6806DDW DA3010F		1	*		
019-1	211423-9	BALL BEARING 6806DDW	O	1		lo	
021	254201-4	klín 4 8419B/DA3010F/11F/BDA		1		kl	
022	763174-5	sklíčidlo komplet DA3010F		1		skl	
023	285842-5	aret. matice sklíčidla DA3010F		1		aret. matice skl	
025	266315-7	TAPPING SCREW MT 4X65		2			
026	418033-5	BAFFLE PLATE		1		deska	
027	635078-0	stator DA3010F		1		stator DA3010F	
028	183560-8	obal DA3010F		1		obal DA3010F	
028		INC. 30					
029	850083-8	NAME PLATE DA3010F		1			
030	819063-3	etiketa Makita		1		etiketa Makita	
031	631516-0	kontrolka DA3010F		1		kontrolka DA3010F	
032	266053-1	šroub 4x35=new266351-3		1			
033	265995-6	šroub 4x18 = old 265941-9		3			
034	183559-3	REAR COVER SET		1		kryt motoru R+L	
034		INC. 39					
035	643801-9	držák uhlíků DA3010F/DA3011F		1		dr	
036	687139-2	kostka DA3010F		1		kostka DA3010F	
037	643801-9	držák uhlíků DA3010F/DA3011F		1		dr	
038	191962-4	uhlíky CB-419 = CB-406,407		1	*	uhl	
038-1	195015-1	CARBON BRUSH SET CB-419	O	1		uhl	
039	183559-3	REAR COVER SET		1		kryt motoru R+L	
039		INC. 34					
040	265995-6	šroub 4x18 = old 265941-9		2			
041	687063-9	CORD CLAMP		1			

042	650539-9	vypínač DA3010F		1		vyp	
043	418038-5	páčka L/R DA3010F/11F		1		p	
044	631527-5	elektronika DA3010F/11F		1		elektronika DA3010F /11F	
045	682559-5	gumová průchodka 6822		1		gumov	
046	666066-6	POWER SUPPLY CORD 1.0-2-2.5		1			
047	213034-6	o kroužek		1			
048	418040-8	CAM		1		va	
049	153477-9	páčka vypínače DA3010F/DA301 1F		1		p	
050	418037-7	SPEED CHANGE DIAL		1		regulace	
A01	411780-7	držák objímky		1			
A02	763415-9	klička S10		1		kli	
A03	152490-4	GRIP 36 COMPLETE		1			

Prosím uveďte objednáč. číslo dílu v objednávce

Datum tisku 17. 10. 2024