

# Model No.HB350 MAGNETIC DRILL

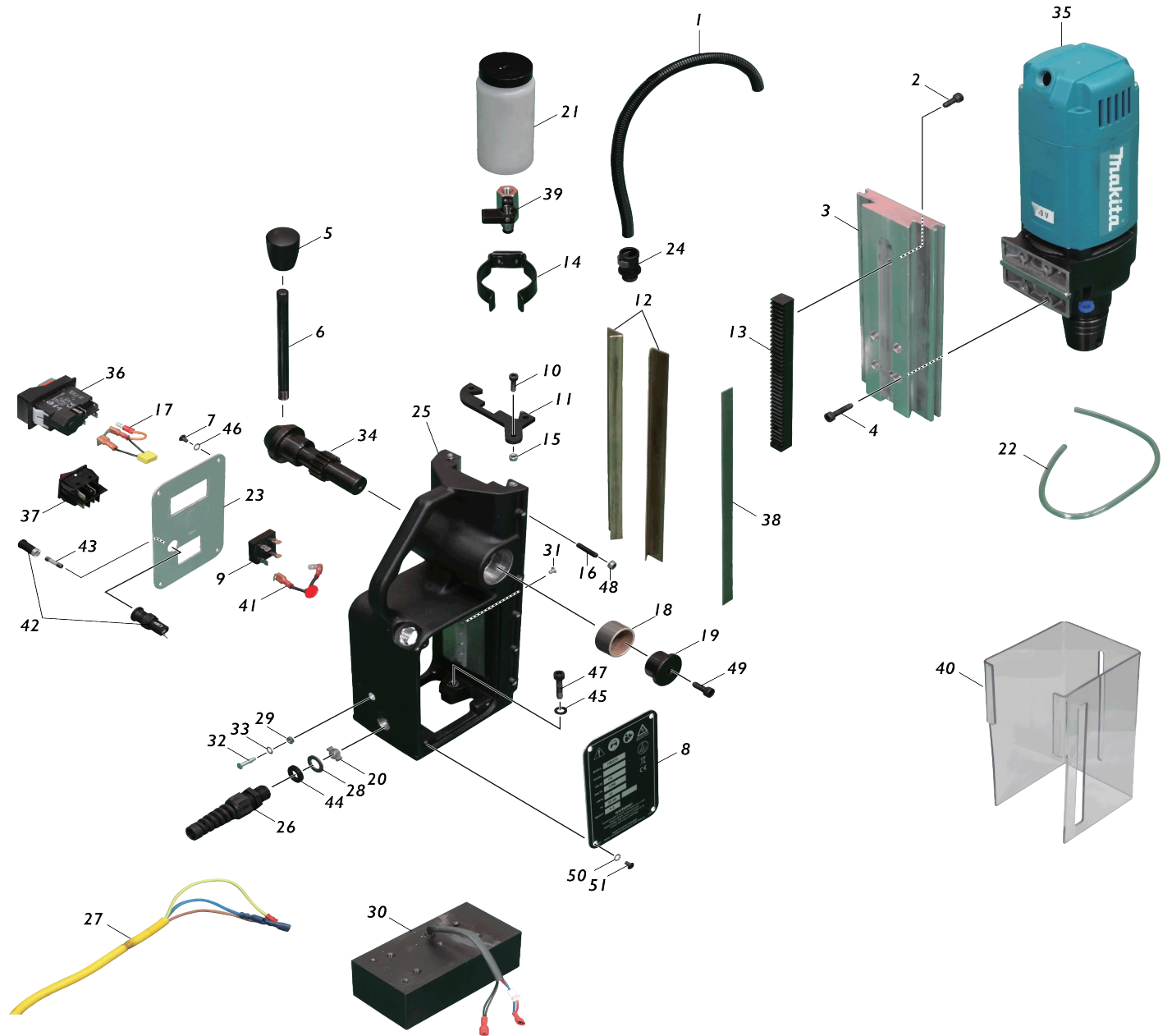

# Model No.HB350 MAGNETIC DRILL

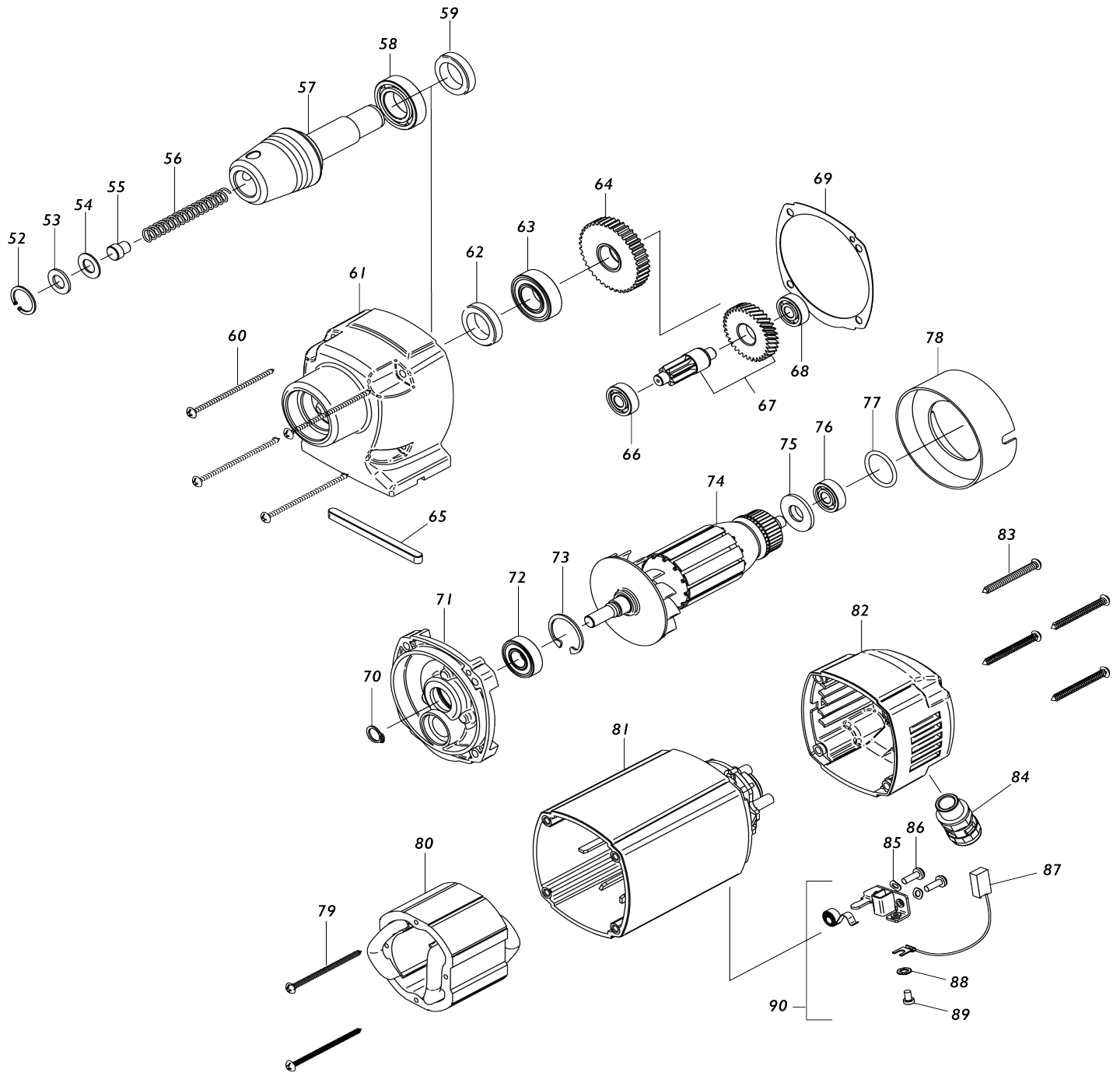

**Model No.HB350 MAGNETIC DRILL**

Obj. č.	Obj. č.	Popis	Možnost záměny	Množství	Nový/Stary	Poznámka 1	Poznámka 2
001	UD000M0443	CONDUIT LARGE 12MM		1		veden	
002	UDSC616CAP	HEX SOCKET HEAD BOLT M6X16		2			
003	UD000M1000	SLIDE		1			
004	UDSC625CAP	HEX SOCKET HEAD BOLT M6X25		4			
005	UD000M0841	HANDLE KNOB		1		dr	
006	UD000BD043	HANDLE(10X130)		1		ty	
007	UD0SC46BUT	H.S. BUTTON HEAD BOLT M4X6		4			
008	UD000M1003	WARNING PLATE HB350 CE		1	*		
008-1	UD000M1048	WARNING PLATE HB350 EU	X	1			
009	UD000M0401	BRIDGE RECTIFIER		1		propojen	
010	UDSC516CAP	HEX SOCKET HEAD BOLT M5X16		3			
011	UD00M0811A	BRACKET		1			
012	UD000M0101	RAIL		2			
013	UD000M0831	RACK		1			
014	UD0010076C	OIL CUP RETAINING RING		1		dr	
015	UD0010085B	M5 NYLOC NUT		1			
016	UD0010085A	M5X25 GRUB SCREW		5			
017	UD0RD43118	CAPACITOR		1	*		
017-1	UD000M1100	CAPACITOR ASSEMBLY	<	1			
018	UD000M0081	PINION BUSH		2			
019	UD000M0072	PINION END CAP (DEEP)		1			
020	UD0RD47179	O CLIP		1			
021	UD0030046A	SMALL OILCUP C/W TAP (BLACK)		1		olejov	
022	UD000BD029	6MM OIL PIPE		1		hadi	
023	UD000M1001	PANEL PLATE		1			
024	UD00040026	M16 GLAND		1		pr	
025	UDM0001BLK	MAIN HOUSING		1			
026	UD00010231	M16 STRAIN RELIEF GLAND		1		koncovka	
027	UD00CLBL04	POWER SUPPLY CORD EU		1	*		
027-1	UD00CABL04	POWER SUPPLY CORD EU	X	1		p	
028	UD0RD47187	FLAT WASHER 10		1			
029	UDNUT-M4-B	HEX NUT M4		1			
030	UD000M1020	MAGNET BASE		1		magnetick	
031	UD0SC46CSK	-COUNTERSUNK HEAD SCREW M 4X6		5			
032	UDSC412CSK	-COUNTERSUNK HEAD SCREW M 4X12		1	*		
032-1	UD412CSK-B	-COUNTERSUNK HEAD SCREW M 4X12	X	1			
033	UD0SPWR-M4	TOOTHED LOCK WASHER 4		1			
034	UD000M0041	PINION		1			
035	UD00EIB523	DRILL UNIT 230V		1		vrta	
036	UD00NCP002	SWITCH(230V)		1		vyp	
037	UD00NCP006	SWITCH		1		vyp	
038	UD000M0441	PLATE		1			
039	UD00050015	COCK		1			
040	UD00VISO18	GUARD		1		chr	
041	UDW18XC521	VARISTOR 20MM 275VRMS		1	*		
041-1	UD000M1104	VARISTOR ASSEMBLY(230V)	<	1			

042	UDW18XC511	FUSE HOLDER		1		
043	UDW18XC512	FUSE		1		
044	UD00UOD009	RUBBER WASHER 10		1		
045	UD0SPWR-M5	FLAT WASHER 6		3	*	
045-1	UD0SPWR-M6	FLAT WASHER 6	X	3		
046	UD0SPWR-M4	TOOTHED LOCK WASHER 4		4		
047	UDSC625CAP	HEX SOCKET HEAD BOLT M6X25		3		
048	UD0010085B	M5 NYLOC NUT		5		
049	UDSC616CAP	HEX SOCKET HEAD BOLT M6X16		1		
050	UD0SPWR-M4	TOOTHED LOCK WASHER 4		4		
051	UD0SC46BUT	H.S. BUTTON HEAD BOLT M4X6		4		
052	UD00EBD030	CIRCLIP		1		
053	UD00EBD029	RUBBER WASHER		1		
054	UD00EBD028	WASHER		1		
055	UD00EBD027	EJECTION PLUG		1		
056	UD00EBD026	COMPRESSION SPRING		1		
057	UD00EIB528	SPINDLE		1		
058	UD00EBD025	BALL BEARING 6904 2RS		1		
059	UD00EBD020	OIL SEAL		1	*	
059-1	UD00EIB184	OIL SEAL	O	1		
060	UD00EBD022	TAPPING SCREW 4.8X60		4		
061	UD00EBD021	GEAR CASE		1		
062	UD00EBD020	OIL SEAL		1	*	
062-1	UD00EIB184	OIL SEAL	O	1		
063	UD00UDC004	BALL BEARING 6003 2RS		1		
064	UD00EBD019	SPINDLE GEAR		1		
065	UD000M1019	KEY		1		
066	UD00UDC022	GROOVED BALL BEARING 608ZZ		1		lo
067	UD00EBD018	INTERNAL SHAFT ASSY		1		
068	UD00UDC022	GROOVED BALL BEARING 608ZZ		1		lo
069	UD00EBD017	GASKET		1		
070	UD00EBD016	CIRCLIP		1		
071	UD00EBD015	GEAR CASE COVER		1		
072	UD00UDC023	GROOVED BALL BEARING 6001Z Z		1		lo
073	UD00EBD014	CIRCLIP		1		
074	UDEBD013-B	ARMATURE 230V		1		rotor HB350
075	UD00EBD012	INSULASION WASHER		1		
076	UD00UDC022	GROOVED BALL BEARING 608ZZ		1		lo
077	UD00EBD011	O-RING		1		
078	UD00EBD010	BAFFLE PLATE		1		
079	UD00EBD009	TAPPING SCREW 3.9X60		2		
080	UDEBD008-B	FIELD 230V		1		stator HB350
081	UD00EIB526	MOTOR HOUSING		1		
082	UD00EIB527	REAR COVER		1		
083	UD00EBD005	TAPPING SCREW 4.8X45		4		
084	UD00040025	PLUG B		1		
085	UD00EBD004	WAVE WASHER 4		2		
086	UD00EBD003	PAN HEAD SCREW M4X12		2		
087	UD00EBD002	CARBON BRUSH		2		
088	UD00EBD031	TOOTHED LOCK WASHER 4		2		
089	UD00EBD032	ROUND HEAD SCREW		2		

090	UD00EBD001	BRUSH HOLDER ASSY		1			
091	UD00PL1889	MAKITA LOGO LABEL		1			
A01	UD00CASE50	CARRY CASE		1			
A02	UD000KEY01	KEY 2.5MM		1			
A03	UD000KEY03	KEY 4MM		1			
A04	UD000KEY04	KEY 5MM		1			
A05	UD0STRAP01	STRAP		1			

Prosím uveďte objednáací číslo dílu v objednávce

Datum tisku 25. 10. 2024